

FEATURES

- Compatible with both conventional and addressable systems
- Large 21.5" LCD display
- Displays active fire zones without user intervention
- Built-in fault output for monitoring
- Remote key switch test facility
- Cloud based media control option
- Pre-configured with site plan and zoning

DESCRIPTION

dynamicZM is a dynamic zone mimic® compatible with a range of addressable and conventional fire alarm control panels from leading manufacturers. Using a large 21.5" LCD screen it displays any active fire alarm zones onto a plan of the protected premises automatically without any user intervention.

Where fire alarm zones are used for remote inputs or non-fire events, specific and bespoke messaging can be applied relating the activated zone on the fire alarm panel.

At all other times **dynamicZM** displays scheduled media content. This can be set at commissioning stage or controlled by the end user through an online media manager platform.

Utilising the power of Yodeck, show eye-catching media on all your **dynamicZM** devices with the push of a button. Just drag & drop your own media into the platform (or choose from thousands of free stock images and videos), and then click 'Push to Players'. For more information go to www.yodeck.com.

Commissioning and zone plan updates are made wirelessly with the **dynamicZM** Engineers Tool program and the on board wi-fi hotspot. Each device has it's own unique SSID credentials for secure connectivity.

dynamicZM is flush mounted as standard offering a sleek and unobtrusive design suitable for numerous applications.

COMPATIBILITY

dynamicZM is compatible with a range of conventional and addressable fire alarm panels from leading manufacturers.



dynamicZM

For more information visit
www.dynamiczm.com



CONNECTION SCHEMATIC

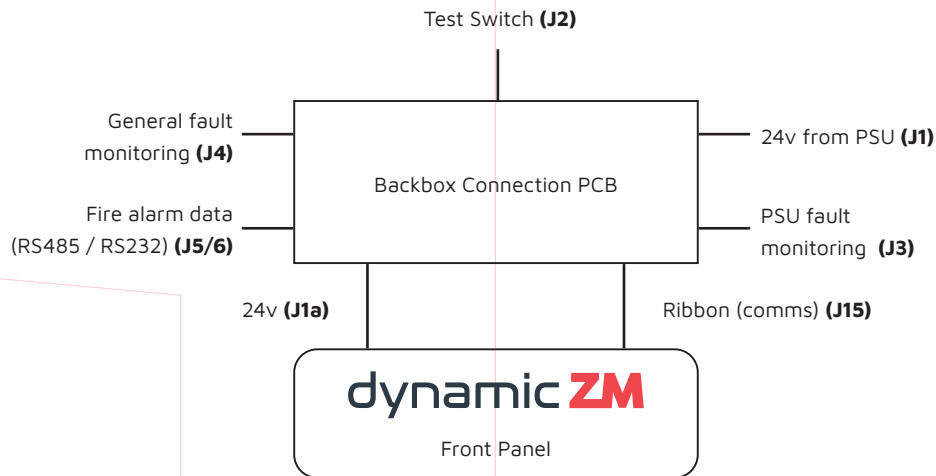

TECHNICAL SPECIFICATIONS

Mechanical & Environmental

Operating Temperature	0°C - 40°C
Power requirement	DC 24V
Weight (screen only)	10Kg

Screen

Dimensions (L x W)	517 x 310mm
LCD Size	21.5"
Resolution	HD 1920x1080
Luminance	300 cd/m ²
Viewing angle	178° (H/V)
Glass	Thermally toughened, EN12150 certified.
LED Life	50,000 hours

Fire alarm loads

Quiescent (standby)	490mA
Alarm (screen on)	1.57A

Connections

Wi-fi (for engineer functions only)	1 x 802.11 a/b/g/n/ ac Wireless LAN
USB (for engineer functions only)	1 x USB 3.2
Network	1 x RJ-45

PRODUCT CODES

DZM-1	dynamicZM
DZM-KE	Kentec Syncro communication interface
DZM-232	RS232 communication interface
DZM-PCB	Replacement connection PCB

COMPATIBILITY

dynamicZM is compatible with a range of conventional and addressable fire alarm panels from leading manufacturers.



dynamic ZM

For more information visit
www.dynamiczm.com

MADE IN BRITAIN[®]

Dynamic Zone Mimic[®] is a registered trademark of Notitia Ignis Ltd. UK Patent Pending.